

36" L x 36" W x 16" H Ready to Finish Kit



**MONTANA
FIRE PITS**

www.montanafirepits.com

CONFIDENTIAL

Any information data and drawings embodied in this document are proprietary and strictly confidential, are to be held as confidential and supplied with the understanding that they will not be disclosed, in whole or in part or in any form, to third parties without the prior written consent of Montana Fire Pits. All information, illustrations, screen shots, and data contained are herein Copyright © Montana Fire Pits. All rights reserved.

Model: 36" L x 36" W x 16" H Ready to Finish Kit

Material: Aluminum frame w/ optional GoBoard

Burner: CFB120 120K BTUs OR CFBO180 180K BTUs

Fuel Pressure: Natural Gas: 7" Water Column
Propane: 11" Water Column

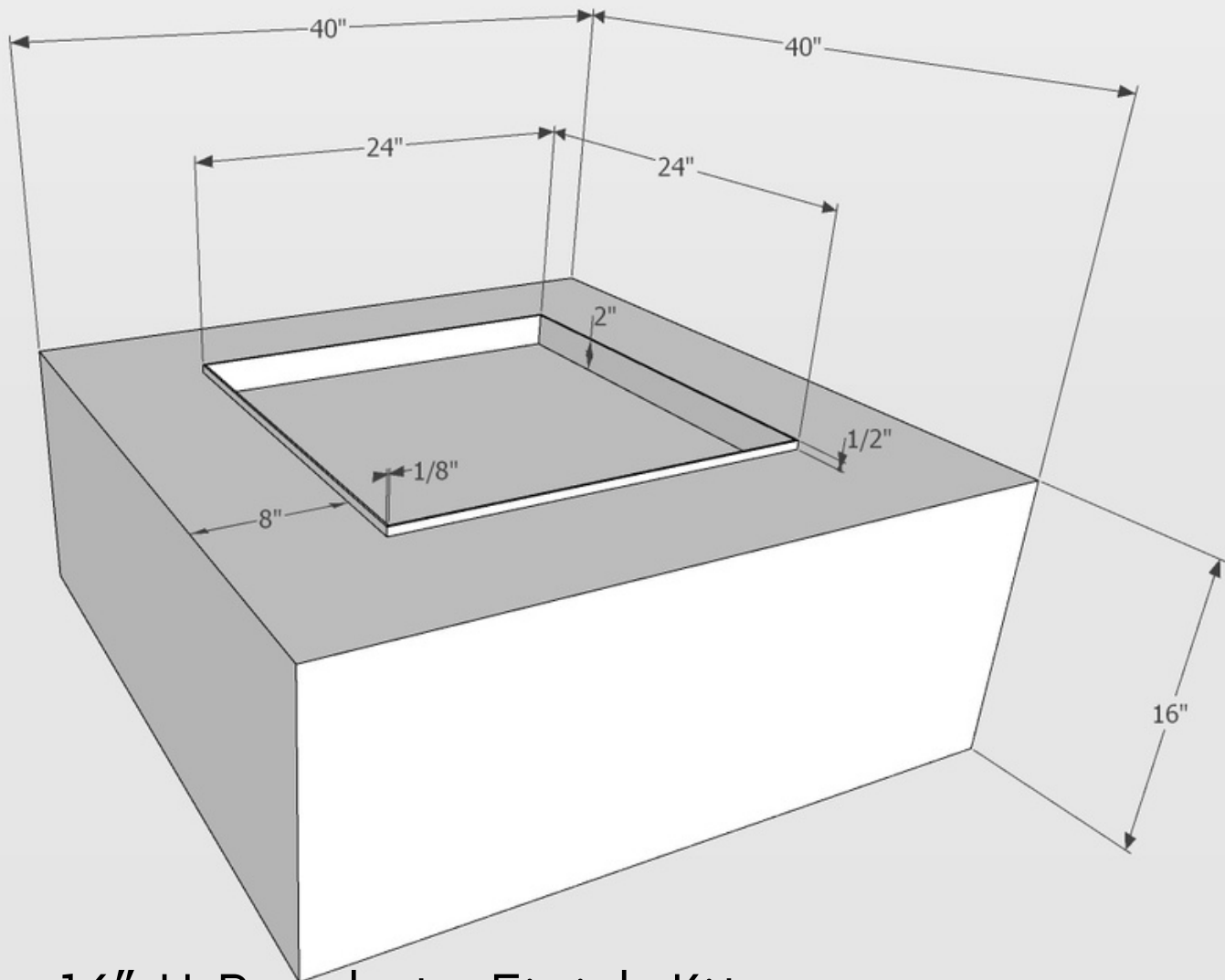

40" L x 40" W x 16" H Ready to Finish Kit



**MONTANA
FIRE PITS**

www.montanafirepits.com

CONFIDENTIAL

Any information data and drawings embodied in this document are proprietary and strictly confidential, are to be held as confidential and supplied with the understanding that they will not be disclosed, in whole or in part or in any form, to third parties without the prior written consent of Montana Fire Pits. All information, illustrations, screen shots, and data contained are herein Copyright © Montana Fire Pits. All rights reserved.

Model: 40" L x 40" W x 16" H Ready to Finish Kit

Material: Aluminum frame w/ optional GoBoard

Burner: CFB120 120K BTUs OR CFBO180 180K BTUs

Fuel Pressure: Natural Gas: 7" Water Column
Propane: 11" Water Column

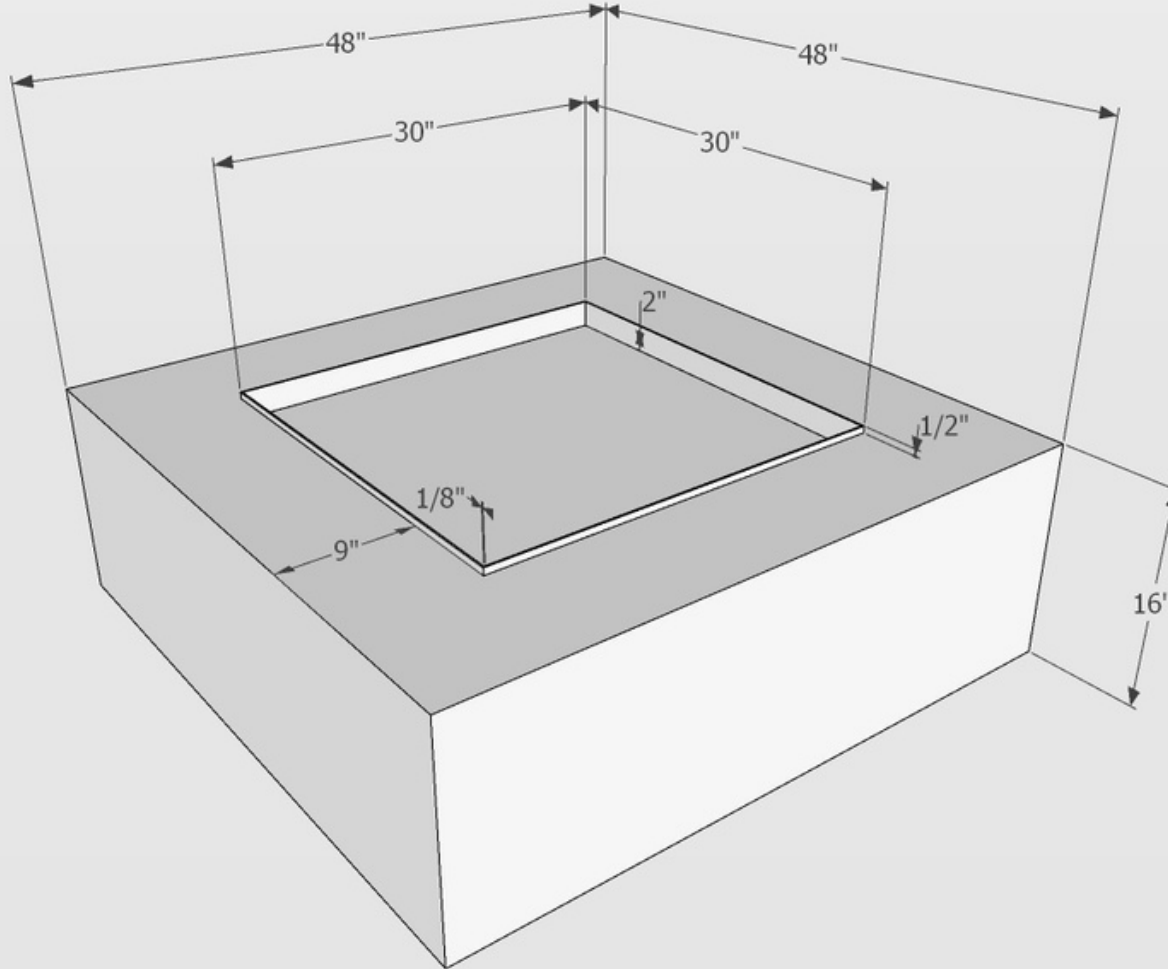

48" L x 48" W x 16" H Ready to Finish Kit



CONFIDENTIAL

Any information data and drawings embodied in this document are proprietary and strictly confidential, are to be held as confidential and supplied with the understanding that they will not be disclosed, in whole or in part or in any form, to third parties without the prior written consent of Montana Fire Pits. All information, illustrations, screen shots, and data contained are herein Copyright © Montana Fire Pits. All rights reserved.

Model: 48" L x 48" W x 16" H Ready to Finish Kit

Material: Aluminum frame w/ optional GoBoard

Burner: CFB180 180K BTUs OR CFBO280 280K BTUs

Fuel Pressure: Natural Gas: 7" Water Column
Propane: 11" Water Column

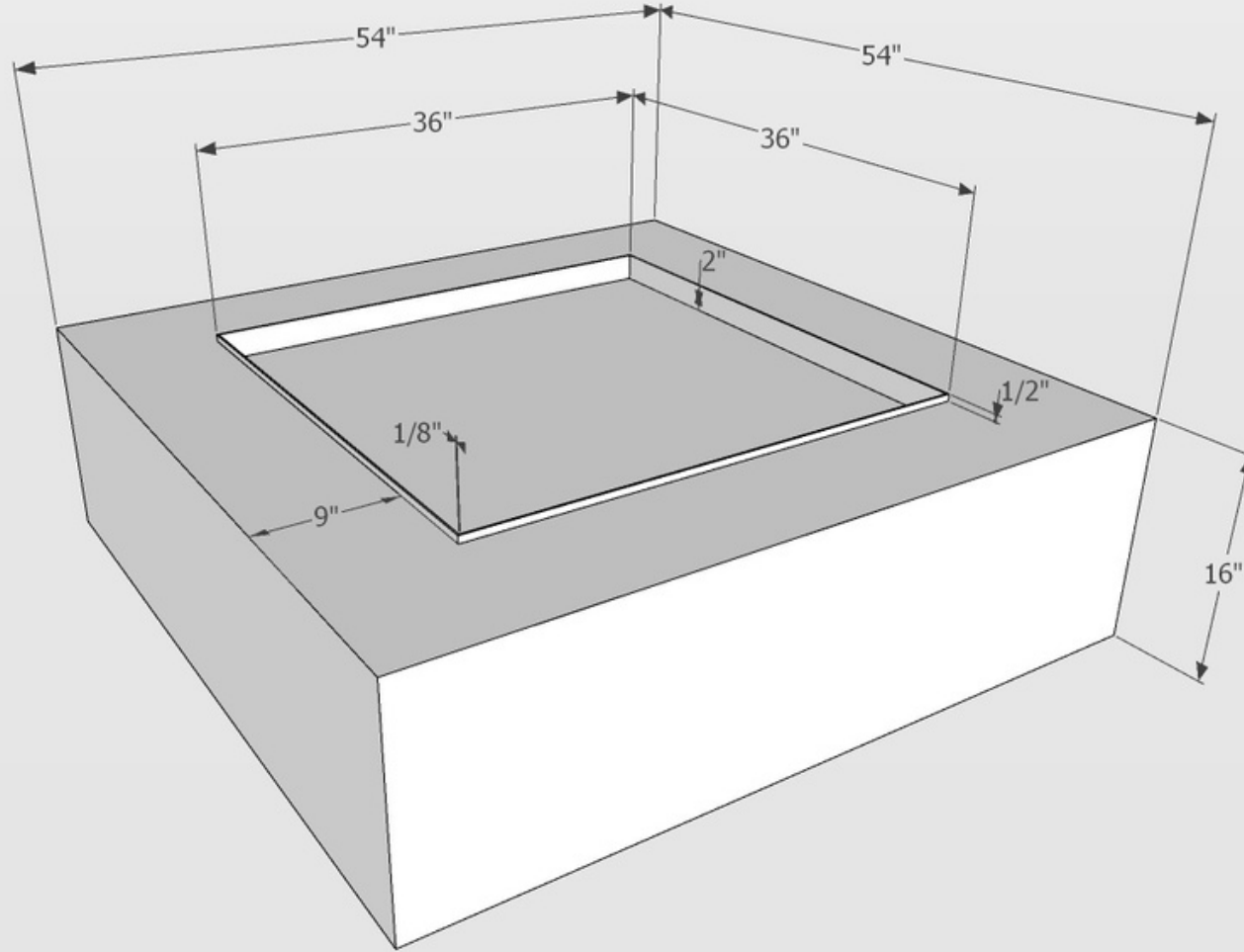

54" L x 54" W x 16" H Ready to Finish Kit



CONFIDENTIAL

Any information data and drawings embodied in this document are proprietary and strictly confidential, are to be held as confidential and supplied with the understanding that they will not be disclosed, in whole or in part or in any form, to third parties without the prior written consent of Montana Fire Pits. All information, illustrations, screen shots, and data contained are herein Copyright © Montana Fire Pits. All rights reserved.

Model: 54" L x 54" W x 16" H Ready to Finish Kit

Material: Aluminum frame w/ optional GoBoard

Burner: CFB290 290K BTUs OR CFBO320 320K BTUs

Fuel Pressure: Natural Gas: 7" Water Column
Propane: 11" Water Column

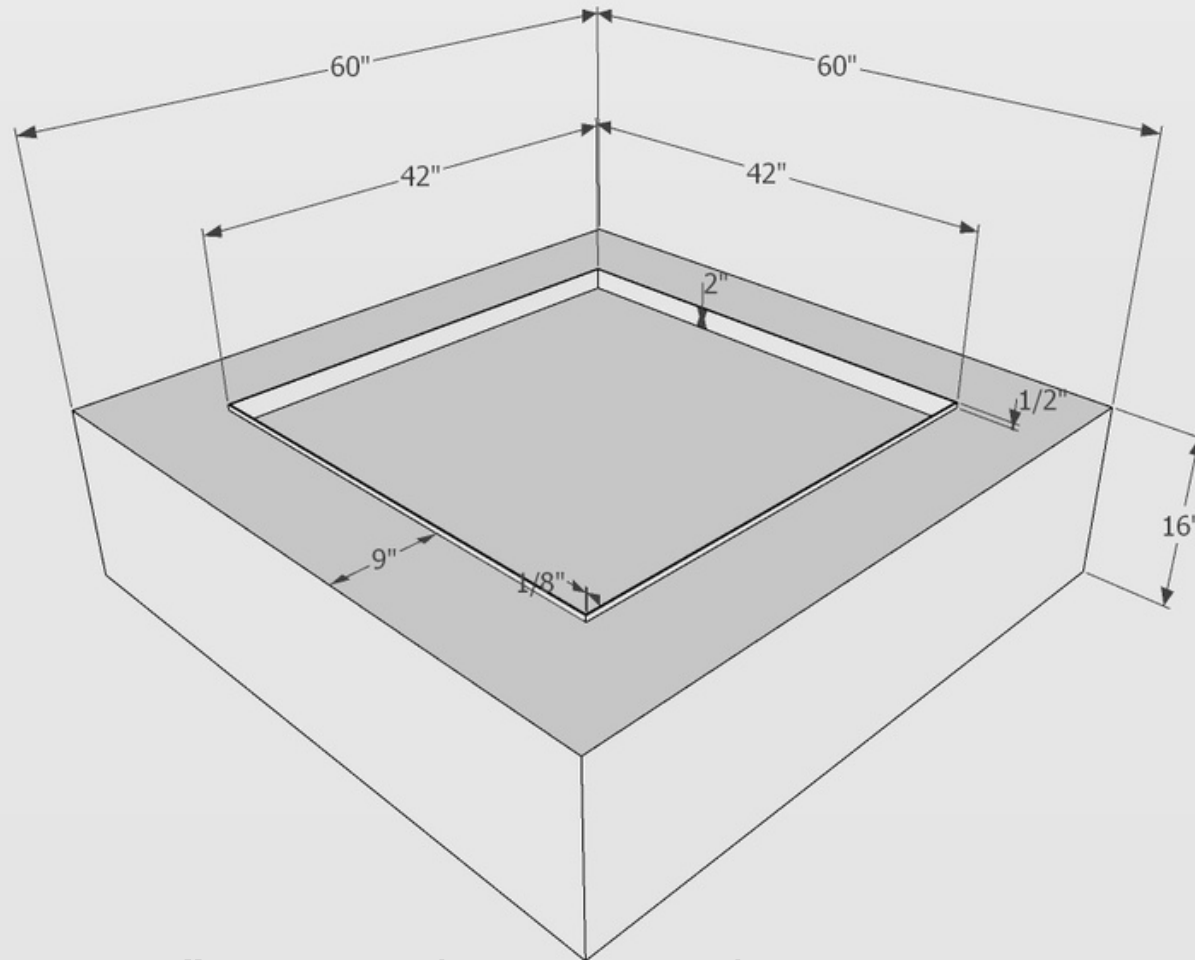

60" L x 60" W x 16" H Ready to Finish Kit



CONFIDENTIAL

Any information data and drawings embodied in this document are proprietary and strictly confidential, are to be held as confidential and supplied with the understanding that they will not be disclosed, in whole or in part or in any form, to third parties without the prior written consent of Montana Fire Pits. All information, illustrations, screen shots, and data contained are herein Copyright © Montana Fire Pits. All rights reserved.

Model: 60" L x 60" W x 16" H Ready to Finish Kit

Material: Aluminum frame w/ optional GoBoard

Burner: CFB300 300K BTUs OR CFBO360 360K BTUs

Fuel Pressure: Natural Gas: 7" Water Column
Propane: 11" Water Column