

**Size:** 32" x 22" x 16"

The Venture Series



## Model: Olympic Studio Fire Table

### Includes:

- Fire Table made of American sourced 3/16" mild steel
- Warming Trends 90K BTU Linear Brass Burner
- 1/2" key valve and flex line kit for flame height adjustment (Installed by others).
- 3" chrome key and finishing plate
- Aluminum burner plate (mounted 4" below the finished top)
- 4" non-marring adjustable feet to create ventilation gap

### Optional Extras:

- matching 3/16" flat steel cover
- Mercury Battery Powered Ignition
- propane regulator w/10 ft hose
- casters

**Fuel Inlet Size:** 1/2" I.D. Female

**Weight:** 150 lbs.

**Fuel Pressure:**

Natural Gas: 7" Water Column  
Propane: 11" Water Column

**Burner:** CFBL90 - 90K BTUs

**Material:** 3/16" Mild Steel

**Protective Finish:** Powder Coating



#### CONFIDENTIAL

Any information data and drawings embodied in this document are proprietary and strictly confidential, are to be held as confidential and supplied with the understanding that they will not be disclosed, in whole or in part or in any form, to third parties without the prior written consent of Montana Fire Pits. All information, illustrations, screen shots, and data contained are herein Copyright © Montana Fire Pits. All rights reserved.

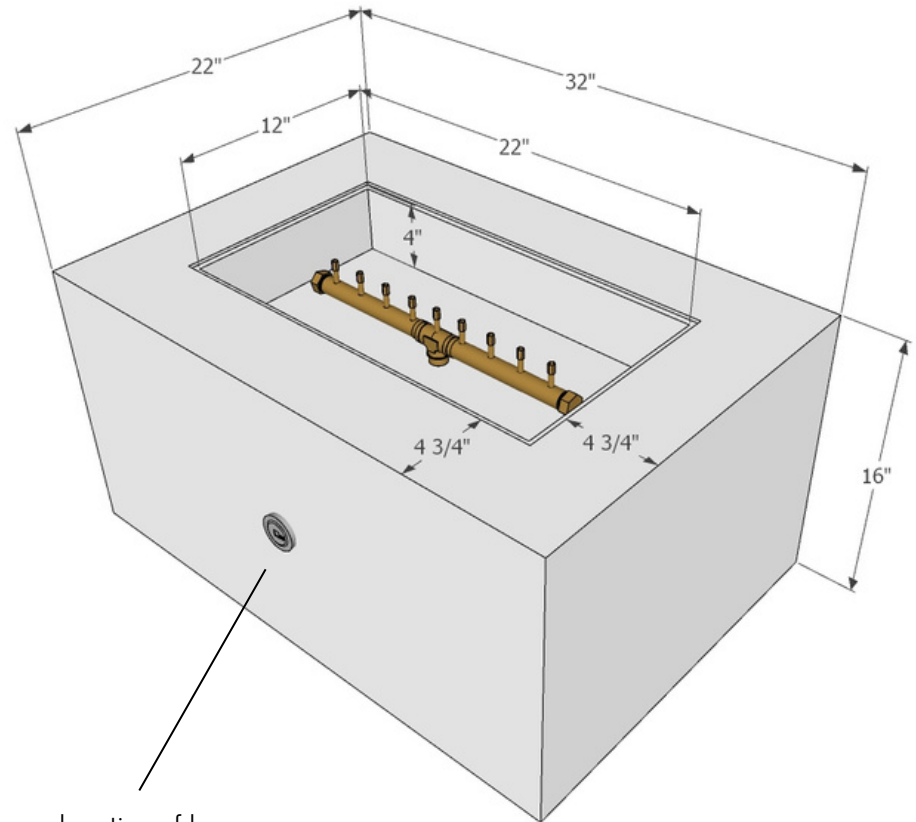

location of key



**Size:** 38" x 22" x 16"

**The Venture Series**



## Model: Olympic Studio Fire Table

### Includes:

- Fire Table made of American sourced 3/16" mild steel
- Warming Trends 110K BTU Linear Brass Burner
- 1/2" key valve and flex line kit for flame height adjustment (Installed by others).
- 3" chrome key and finishing plate
- Aluminum burner plate (mounted 4" below the finished top)
- 4" non-marring adjustable feet to create ventilation gap

### Optional Extras:

- matching 3/16" flat steel cover
- Mercury Battery Powered Ignition
- propane regulator w/10 ft hose
- casters

**Fuel Inlet Size:** 1/2" I.D. Female

**Weight:** 180 lbs.

**Fuel Pressure:**

Natural Gas: 7" Water Column  
Propane: 11" Water Column

**Burner:** CFBL110 - 110K BTUs

**Material:** 3/16" Mild Steel

**Protective Finish:** Powder Coating



#### CONFIDENTIAL

Any information data and drawings embodied in this document are proprietary and strictly confidential, are to be held as confidential and supplied with the understanding that they will not be disclosed, in whole or in part or in any form, to third parties without the prior written consent of Montana Fire Pits. All information, illustrations, screen shots, and data contained are herein Copyright © Montana Fire Pits. All rights reserved.

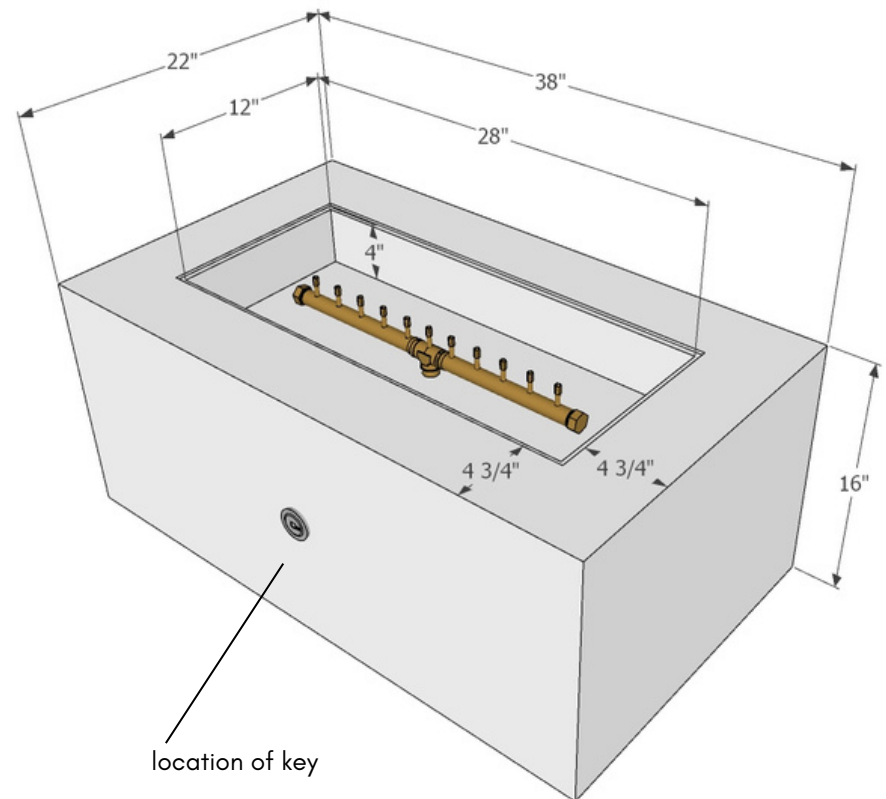

**Size: 42" x 22" x 16"**

**The Venture Series**



## Model: Olympic Studio Fire Table

### Includes:

- Fire Table made of American sourced 3/16" mild steel
- Warming Trends 130K BTU Linear Brass Burner
- 1/2" key valve and flex line kit for flame height adjustment (Installed by others).
- 3" chrome key and finishing plate
- Aluminum burner plate (mounted 4" below the finished top)
- 4" non-marring adjustable feet to create ventilation gap

### Optional Extras:

- matching 3/16" flat steel cover
- Mercury Battery Powered Ignition
- propane regulator w/10 ft hose
- casters

**Fuel Inlet Size:** 1/2" I.D. Female

**Weight:** 210 lbs.

**Fuel Pressure:**

Natural Gas: 7" Water Column  
Propane: 11" Water Column

**Burner:** CFBL130 - 130K BTUs

**Material:** 3/16" Mild Steel

**Protective Finish:** Powder Coating



#### CONFIDENTIAL

Any information data and drawings embodied in this document are proprietary and strictly confidential, are to be held as confidential and supplied with the understanding that they will not be disclosed, in whole or in part or in any form, to third parties without the prior written consent of Montana Fire Pits. All information, illustrations, screen shots, and data contained are herein Copyright © Montana Fire Pits. All rights reserved.

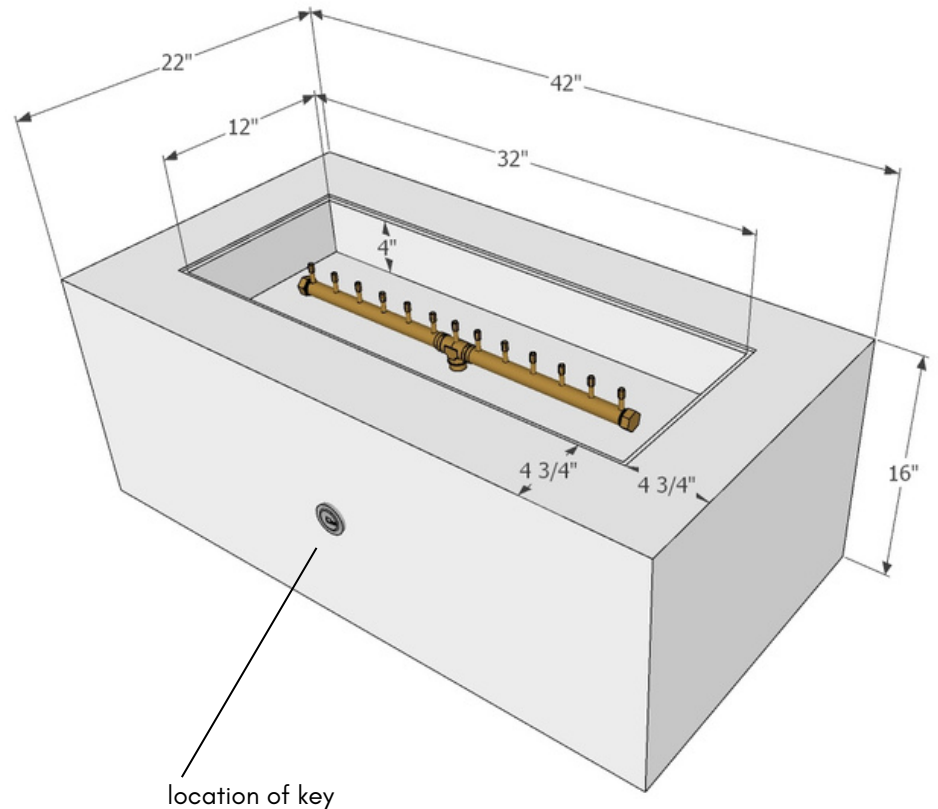

**Size: 48" x 22" x 16"**

**The Venture Series**



## Model: **Olympic Studio Fire Table**

### Includes:

- Fire Table made of American sourced 3/16" mild steel
- Warming Trends 150K BTU Linear Brass Burner
- 1/2" key valve and flex line kit for flame height adjustment (Installed by others).
- 3" chrome key and finishing plate
- Aluminum burner plate (mounted 4" below the finished top)
- 4" non-marring adjustable feet to create ventilation gap

### Optional Extras:

- matching 3/16" flat steel cover
- Mercury Battery Powered Ignition
- propane regulator w/10 ft hose
- casters

**Fuel Inlet Size:** 1/2" I.D. Female

**Weight:** 250 lbs.

### Fuel Pressure:

Natural Gas: 7" Water Column  
Propane: 11" Water Column

**Burner:** CFBL150 - 150K BTUs

**Material:** 3/16" Mild Steel

**Protective Finish:** Powder Coating



### CONFIDENTIAL

Any information data and drawings embodied in this document are proprietary and strictly confidential, are to be held as confidential and supplied with the understanding that they will not be disclosed, in whole or in part or in any form, to third parties without the prior written consent of Montana Fire Pits. All information, illustrations, screen shots, and data contained are herein Copyright © Montana Fire Pits. All rights reserved.

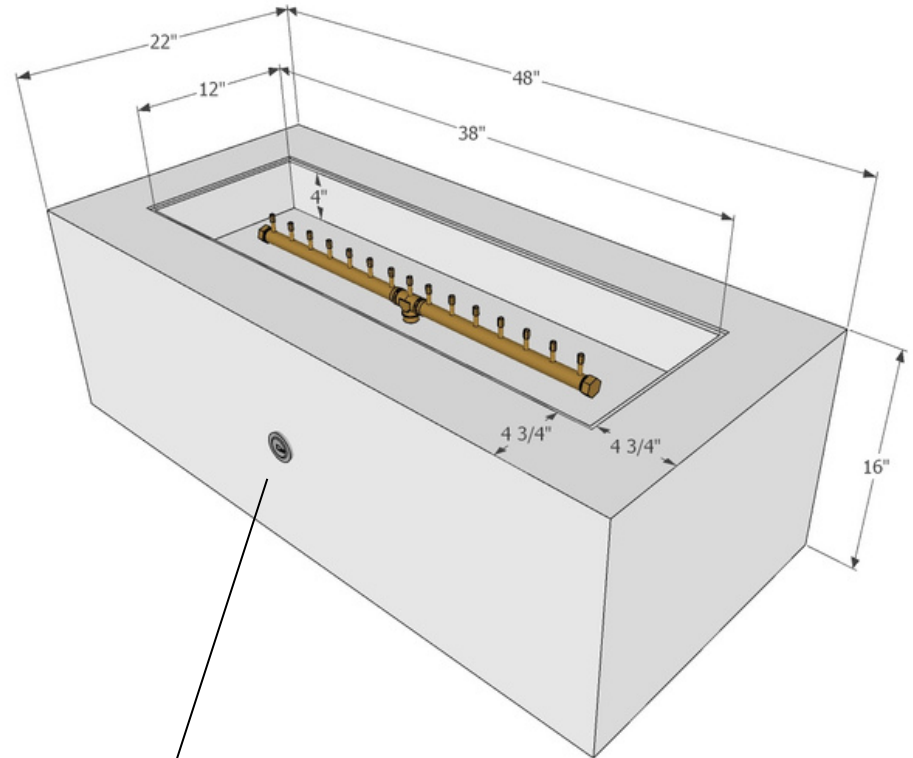

location of key

