

Size: 35" DIA x 16" H

The Gather Series

Model: Toba Fire Table

Includes:

- Fire Table made of Glass Fiber Reinforced Concrete
- Warming Trends Crossfire Brass Burner (see options)
- 3/4" key valve and flex line kit for flame height adjustment (Installed by others).
- 4" chrome key and finishing plate
- Aluminum burner plate (mounted 4" below the finished top)

Optional Extras:

- Powder Coated Aluminum Flat Tabletop Cover
- Platinum Electronic Ignition
- Matching Concrete Propane Tank Enclosure

Fuel Inlet Size: 3/4" I.D. Female

Weight: 250 lbs.

Fuel Pressure: Natural Gas: 7" Water Column
Propane: 11" Water Column

Standard Burner: CFBCT120 - 120K BTUs Circle Tree
OR upgrade to CFBO140 - 140K BTUs Octagonal

Material: Glass Fiber Reinforced Concrete



CONFIDENTIAL

Any information data and drawings embodied in this document are proprietary and strictly confidential, are to be held as confidential and supplied with the understanding that they will not be disclosed, in whole or in part or in any form, to third parties without the prior written consent of Montana Fire Pits. All information, illustrations, screen shots, and data contained are herein Copyright © Montana Fire Pits. All rights reserved.

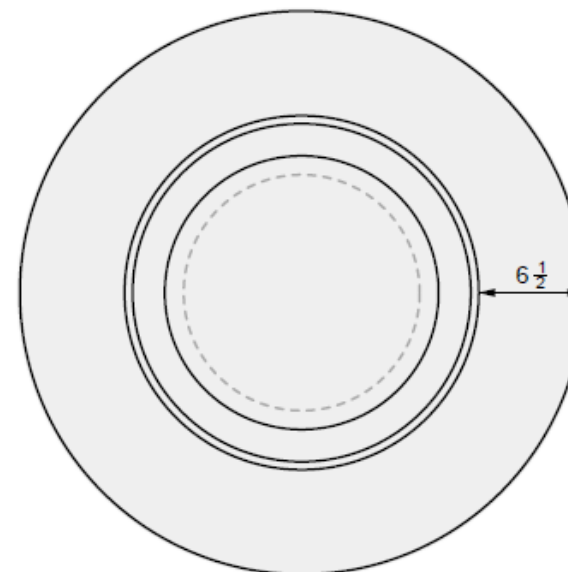

01 TOP VIEW

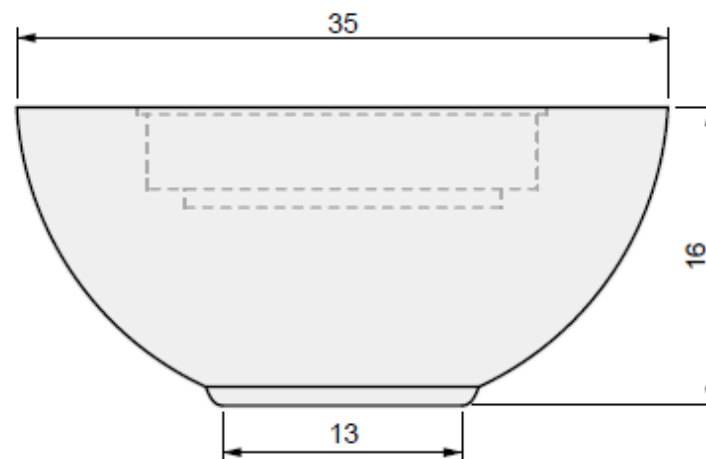

02 FRONT VIEW

Size: 35" DIA x 16" H

Model: Toba Fire Table



CONFIDENTIAL

Any information data and drawings embodied in this document are proprietary and strictly confidential, are to be held as confidential and supplied with the understanding that they will not be disclosed, in whole or in part or in any form, to third parties without the prior written consent of Montana Fire Pits. All information, illustrations, screen shots, and data contained are herein Copyright © Montana Fire Pits. All rights reserved.

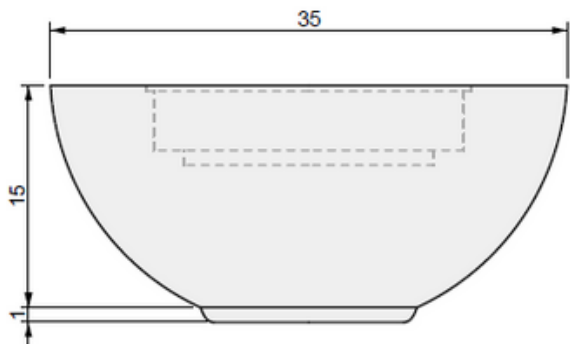

03 SIDE VIEW

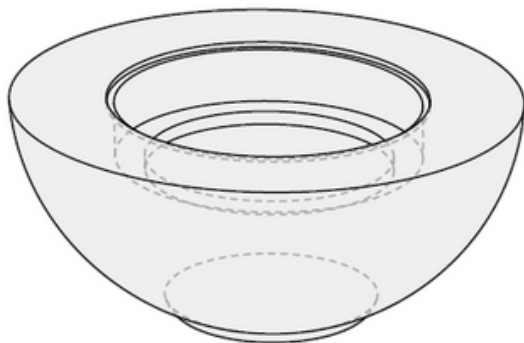

04 PERSPECTIVE

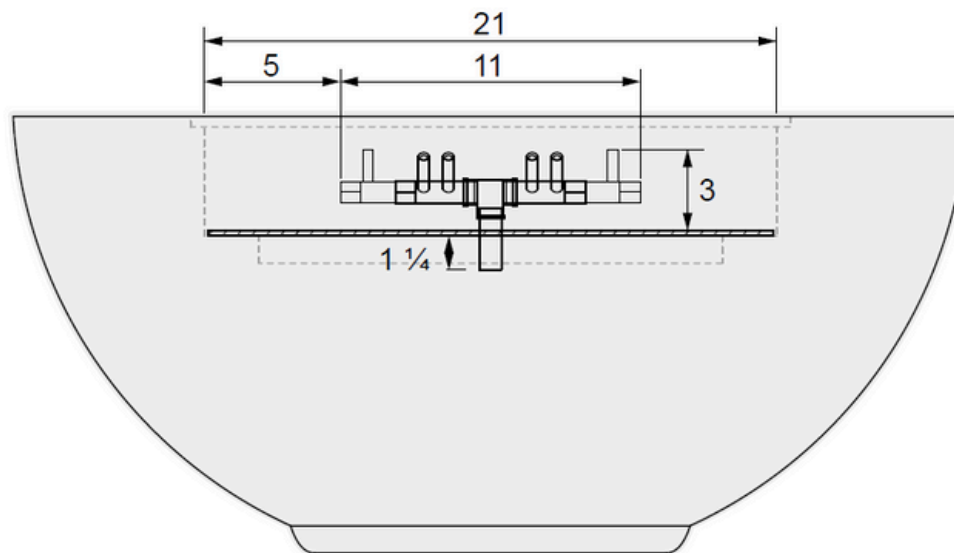

01 SIDE VIEW

BURNER MODEL

CIRCLE TREE-STYLE CFBCTL120

Dimensions: 11" x 10"
120,000 BTU

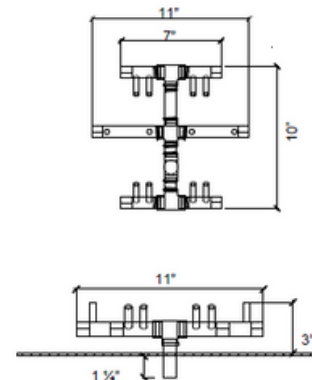

Size: 35" DIA x 16" H

Model: Toba Fire Table



CONFIDENTIAL

Any information data and drawings embodied in this document are proprietary and strictly confidential, are to be held as confidential and supplied with the understanding that they will not be disclosed, in whole or in part or in any form, to third parties without the prior written consent of Montana Fire Pits. All information, illustrations, screen shots, and data contained are herein Copyright © Montana Fire Pits. All rights reserved.

Burner Plate

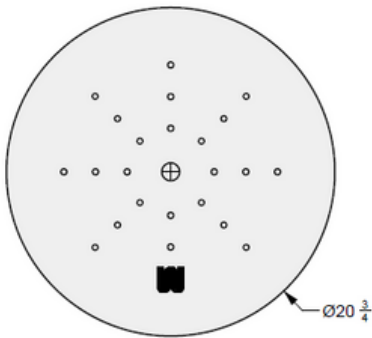

01 TOP VIEW

02 FRONT VIEW

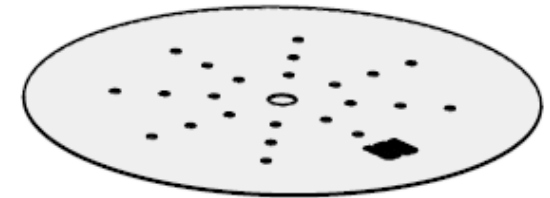

03 PERSPECTIVE

Optional Flat Tabletop Cover

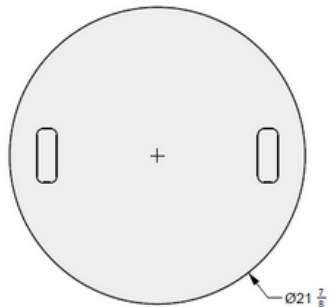

01 TOP VIEW

02 FRONT VIEW



03 PERSPECTIVE

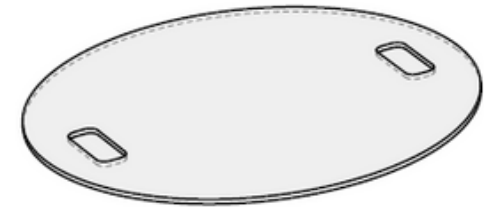

Size: 38" DIA x 16" H

The Gather Series

Model: Toba Fire Table

Includes:

- Fire Table made of Glass Fiber Reinforced Concrete
- Warming Trends Crossfire Brass Burner (see options)
- 3/4" key valve and flex line kit for flame height adjustment (Installed by others).
- 4" chrome key and finishing plate
- Aluminum burner plate (mounted 4" below the finished top)

Optional Extras:

- Powder Coated Aluminum Flat Tabletop Cover
- Platinum Electronic Ignition
- Matching Concrete Propane Tank Enclosure

Fuel Inlet Size: 3/4" I.D. Female

Weight: 280 lbs.

Fuel Pressure: Natural Gas: 7" Water Column
Propane: 11" Water Column

Standard Burner: CFBCT120 - 120K BTUs Circle Tree
OR upgrade to CFBO140 - 140K BTUs Octagonal

Material: Glass Fiber Reinforced Concrete



CONFIDENTIAL

Any information data and drawings embodied in this document are proprietary and strictly confidential, are to be held as confidential and supplied with the understanding that they will not be disclosed, in whole or in part or in any form, to third parties without the prior written consent of Montana Fire Pits. All information, illustrations, screen shots, and data contained are herein Copyright © Montana Fire Pits. All rights reserved.

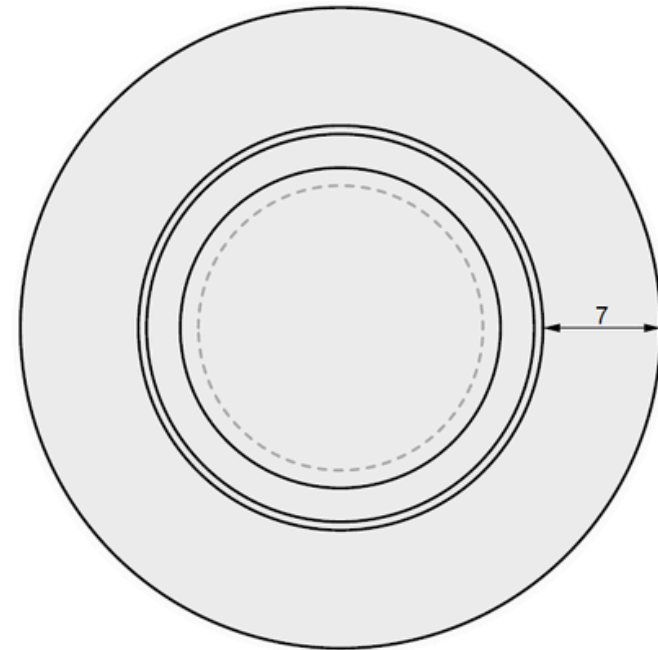

01 TOP VIEW

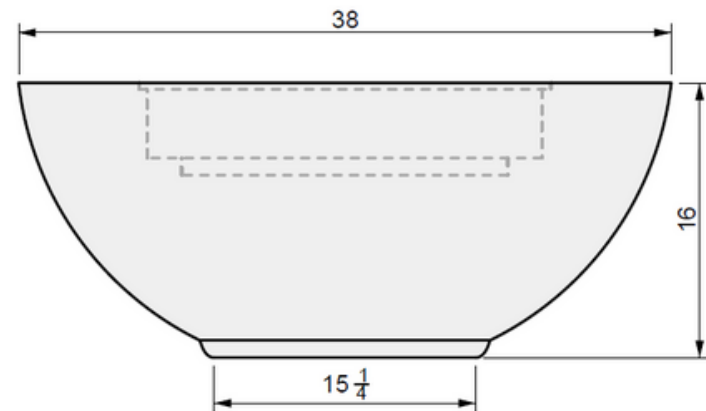

02 FRONT VIEW

Size: 38" DIA x 16" H

Model: Toba Fire Table



CONFIDENTIAL

Any information data and drawings embodied in this document are proprietary and strictly confidential, are to be held as confidential and supplied with the understanding that they will not be disclosed, in whole or in part or in any form, to third parties without the prior written consent of Montana Fire Pits. All information, illustrations, screen shots, and data contained are herein Copyright © Montana Fire Pits. All rights reserved.

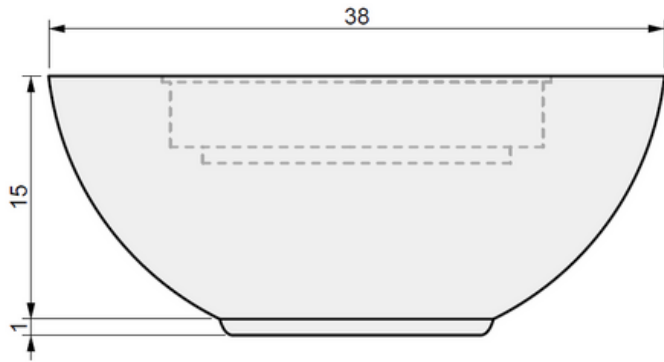

03 SIDE VIEW

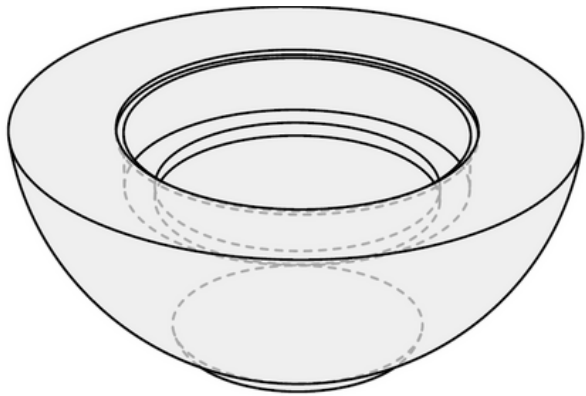

04 PERSPECTIVE

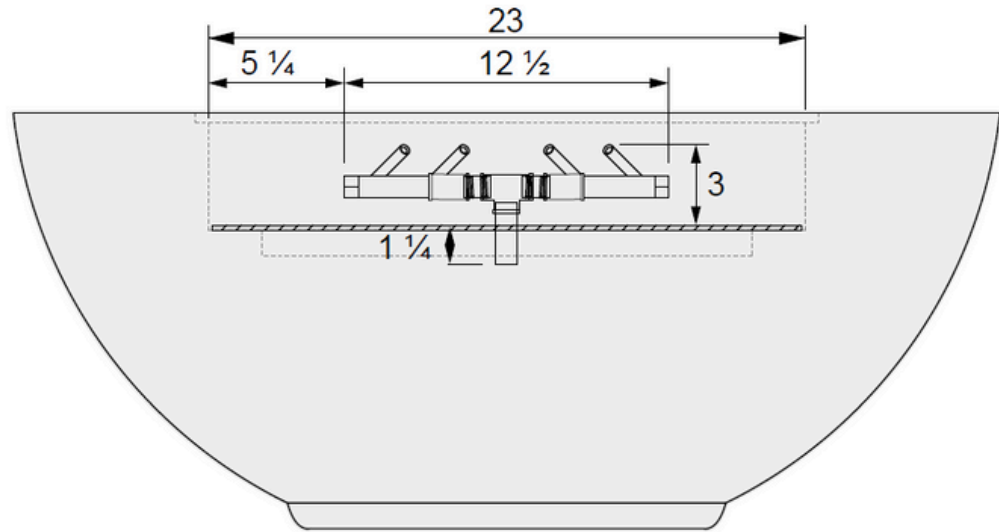

01 SIDE VIEW

BURNER MODEL

OCTAGONAL CFBO140
Dimensions: 14.5" x 12.5"
140,000 BTU

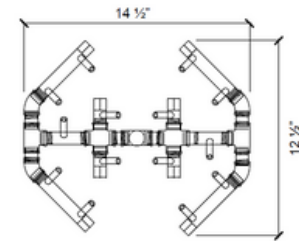
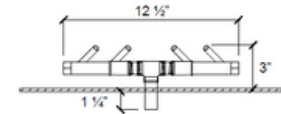

Size: 38" DIA x 16" H

Model: Toba Fire Table



CONFIDENTIAL

Any information data and drawings embodied in this document are proprietary and strictly confidential, are to be held as confidential and supplied with the understanding that they will not be disclosed, in whole or in part or in any form, to third parties without the prior written consent of Montana Fire Pits. All information, illustrations, screen shots, and data contained are herein Copyright © Montana Fire Pits. All rights reserved.

Burner Plate

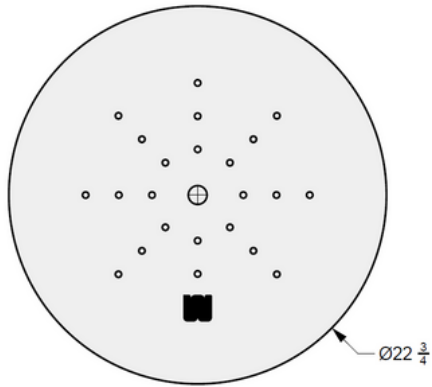

01 TOP VIEW

02 FRONT VIEW

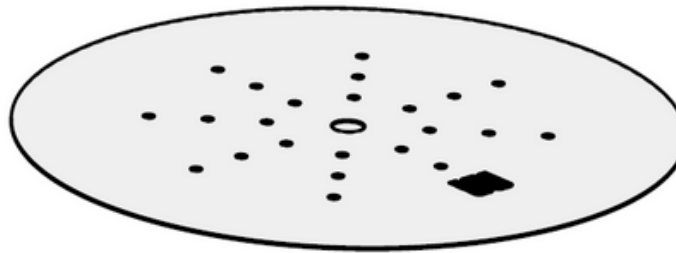
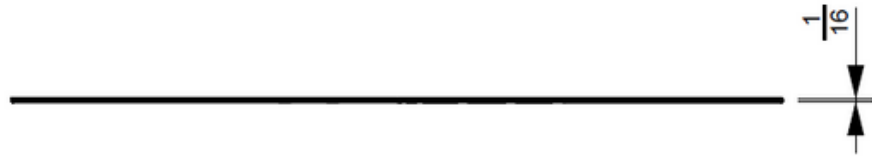

03 PERSPECTIVE

Optional Flat Tabletop Cover

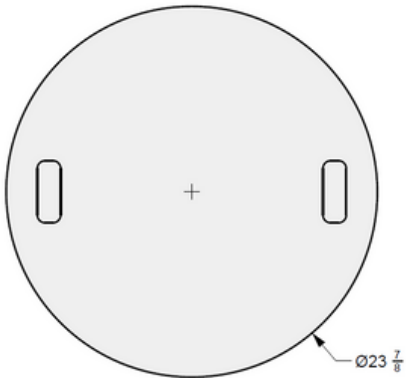

01 TOP VIEW



02 FRONT VIEW

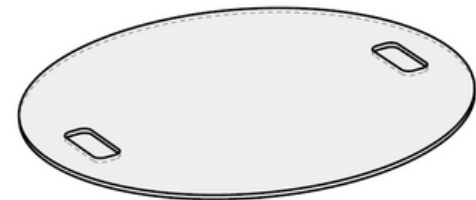

03 PERSPECTIVE

Size: **45" DIA x 16" H**

The Gather Series

Model: **Toba Fire Table**

Includes:

- Fire Table made of Glass Fiber Reinforced Concrete
- Warming Trends Crossfire Brass Burner
- 3/4" key valve and flex line kit for flame height adjustment (Installed by others).
- 4" chrome key and finishing plate
- Aluminum burner plate (mounted 4" below the finished top)

Optional Extras:

- Powder Coated Aluminum Flat Tabletop Cover
- Platinum Electronic Ignition
- Matching Concrete Propane Tank Enclosure

Fuel Inlet Size: 3/4" I.D. Female

Weight: 300 lbs.

Fuel Pressure: Natural Gas: 7" Water Column
Propane: 11" Water Column

Burner: CFBO180 - 180K BTUs Octagonal Burner

Material: Glass Fiber Reinforced Concrete



CONFIDENTIAL

Any information data and drawings embodied in this document are proprietary and strictly confidential, are to be held as confidential and supplied with the understanding that they will not be disclosed, in whole or in part or in any form, to third parties without the prior written consent of Montana Fire Pits. All information, illustrations, screen shots, and data contained are herein Copyright © Montana Fire Pits. All rights reserved.

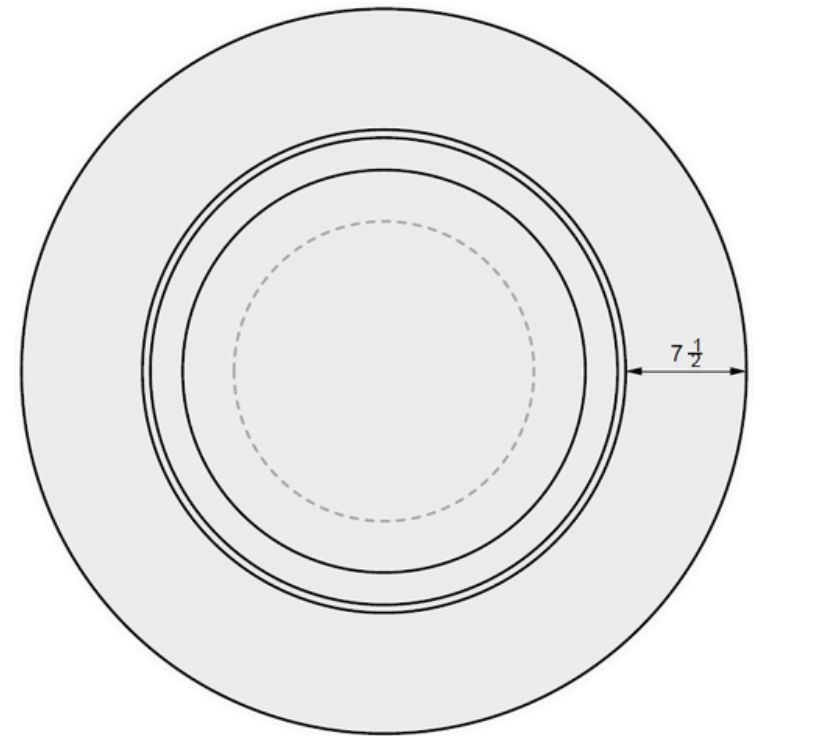

01 TOP VIEW

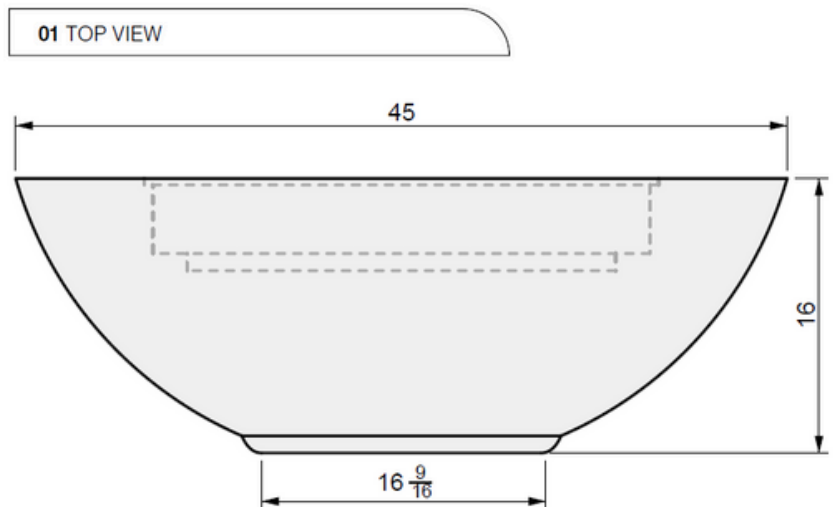

02 FRONT VIEW

Size: 45" DIA x 16" H

Model: Toba Fire Table



CONFIDENTIAL

Any information data and drawings embodied in this document are proprietary and strictly confidential, are to be held as confidential and supplied with the understanding that they will not be disclosed, in whole or in part or in any form, to third parties without the prior written consent of Montana Fire Pits. All information, illustrations, screen shots, and data contained are herein Copyright © Montana Fire Pits. All rights reserved.

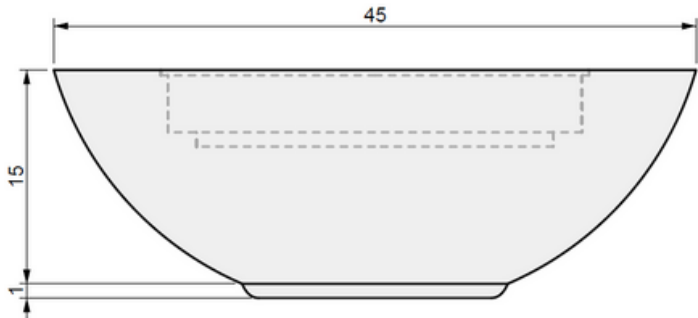

03 SIDE VIEW

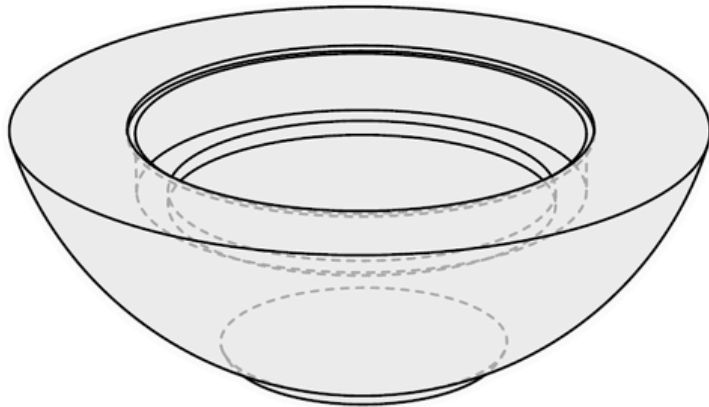

04 PERSPECTIVE

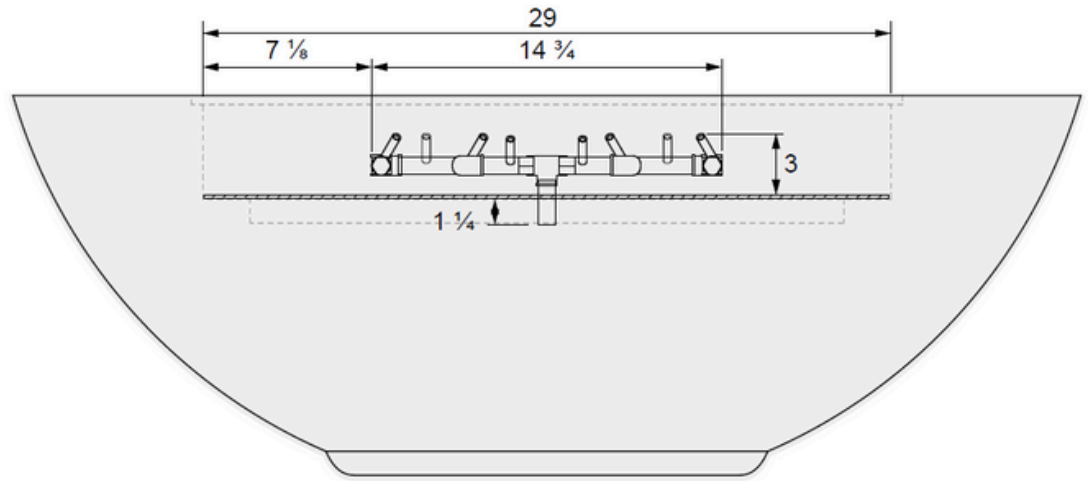

01 SIDE VIEW

BURNER MODEL

OCTAGONAL CFBO180
Dimensions: 15.75" x 14.75"
180,000 BTU

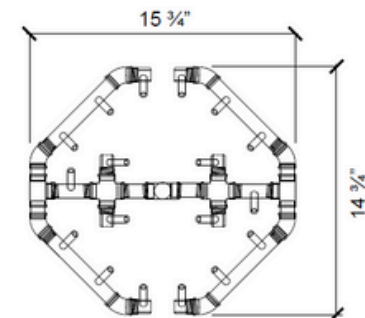
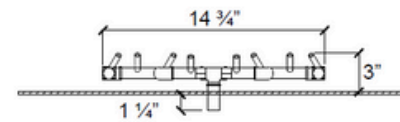

Size: 45" DIA x 16" H

Model: Toba Fire Table



CONFIDENTIAL

Any information data and drawings embodied in this document are proprietary and strictly confidential, are to be held as confidential and supplied with the understanding that they will not be disclosed, in whole or in part or in any form, to third parties without the prior written consent of Montana Fire Pits. All information, illustrations, screen shots, and data contained are herein Copyright © Montana Fire Pits. All rights reserved.

Burner Plate

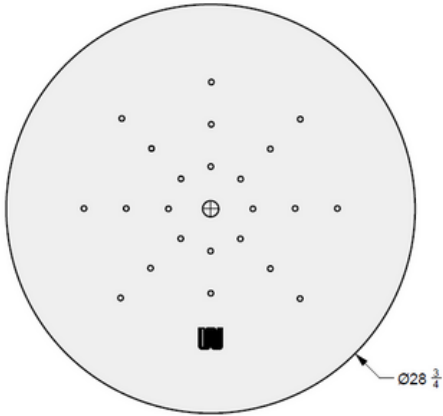

01 TOP VIEW

02 FRONT VIEW

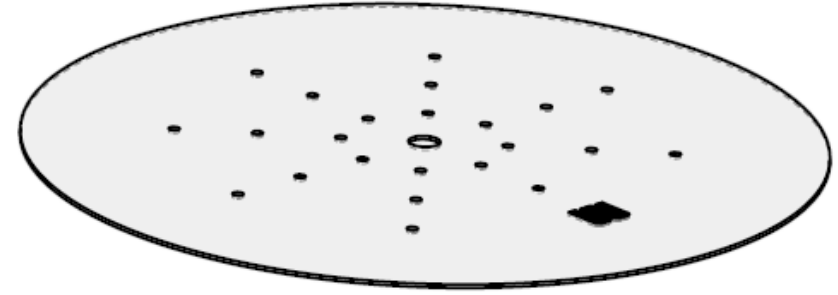

03 PERSPECTIVE

Optional Flat Tabletop Cover

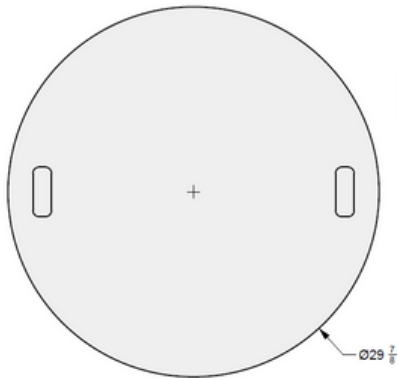

01 TOP VIEW

02 FRONT VIEW

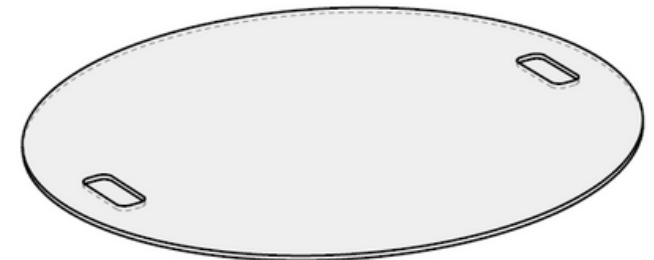

03 PERSPECTIVE

Size: 52" DIA x 16" H

The Gather Series

Model: Toba Fire Table

Includes:

- Fire Table made of Glass Fiber Reinforced Concrete
- Warming Trends Crossfire Brass Burner
- 3/4" key valve and flex line kit for flame height adjustment (Installed by others).
- 4" chrome key and finishing plate
- Aluminum burner plate (mounted 4" below the finished top)

Optional Extras:

- Powder Coated Aluminum Flat Tabletop Cover
- Platinum Electronic Ignition
- Matching Concrete Propane Tank Enclosure

Fuel Inlet Size: 3/4" I.D. Female

Weight: 350 lbs.

Fuel Pressure: Natural Gas: 7" Water Column
Propane: 11" Water Column

Standard Burner: CFB240 - 240K BTUs Original
OR CFBO280 - 280K BTUs Octagonal

Material: Glass Fiber Reinforced Concrete



CONFIDENTIAL

Any information data and drawings embodied in this document are proprietary and strictly confidential, are to be held as confidential and supplied with the understanding that they will not be disclosed, in whole or in part or in any form, to third parties without the prior written consent of Montana Fire Pits. All information, illustrations, screen shots, and data contained are herein Copyright © Montana Fire Pits. All rights reserved.

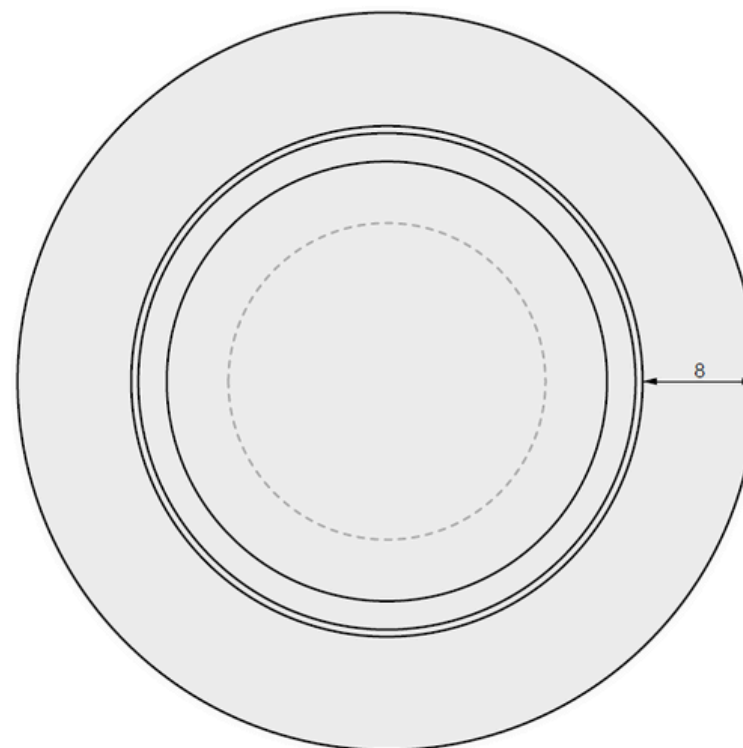

01 TOP VIEW

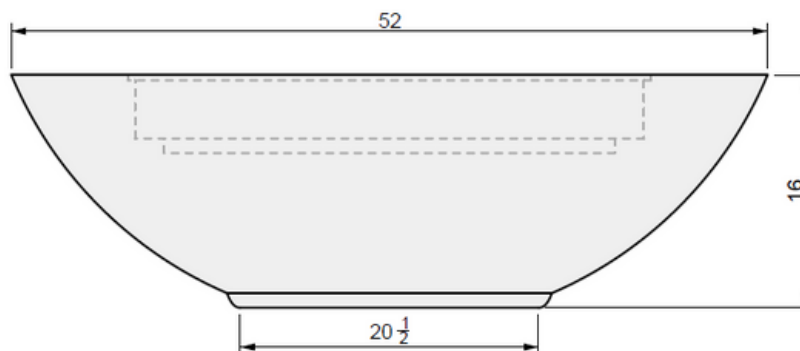

02 FRONT VIEW

Size: 52" DIA x 16" H

Model: Toba Fire Table



CONFIDENTIAL

Any information data and drawings embodied in this document are proprietary and strictly confidential, are to be held as confidential and supplied with the understanding that they will not be disclosed, in whole or in part or in any form, to third parties without the prior written consent of Montana Fire Pits. All information, illustrations, screen shots, and data contained are herein Copyright © Montana Fire Pits. All rights reserved.

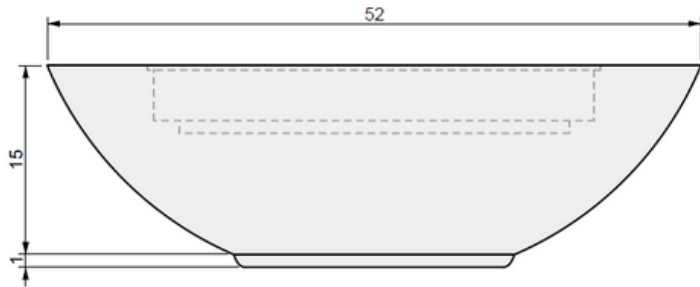

03 SIDE VIEW

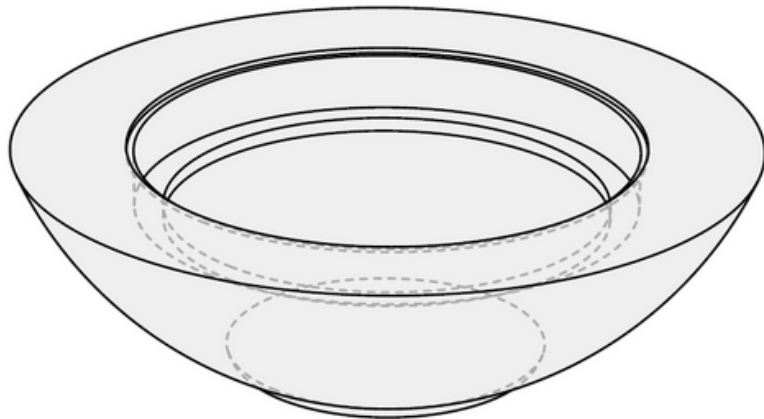

04 PERSPECTIVE

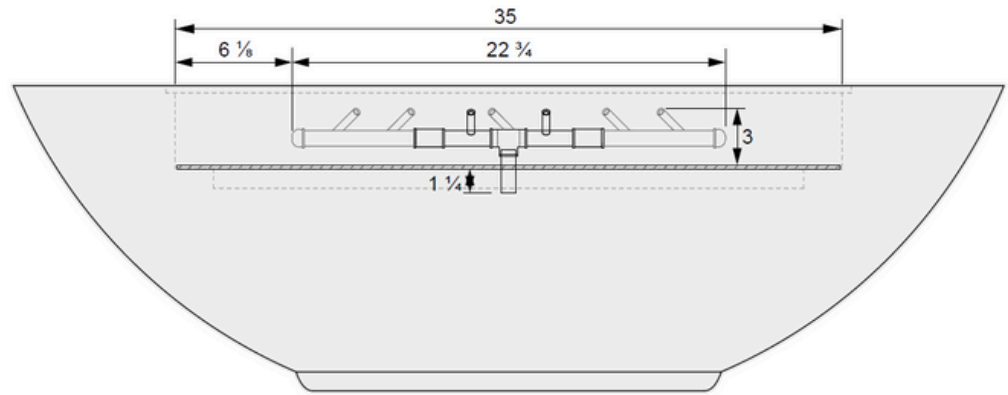

01 SIDE VIEW

BURNER MODEL

OCTAGONAL CFBO280
Dimensions: 21.75" x 22.75"
280,000 BTU

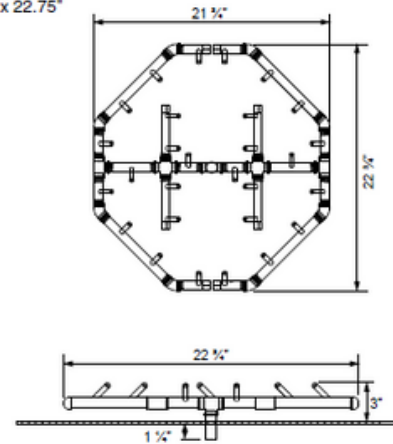

Size: 52" DIA x 16" H

Model: Toba Fire Table



CONFIDENTIAL

Any information data and drawings embodied in this document are proprietary and strictly confidential, are to be held as confidential and supplied with the understanding that they will not be disclosed, in whole or in part or in any form, to third parties without the prior written consent of Montana Fire Pits. All information, illustrations, screen shots, and data contained are herein Copyright © Montana Fire Pits. All rights reserved.

Burner Plate

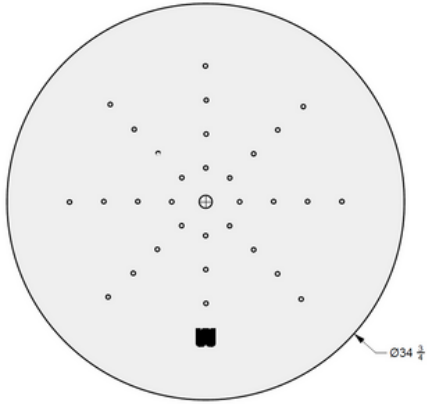

01 TOP VIEW

02 FRONT VIEW

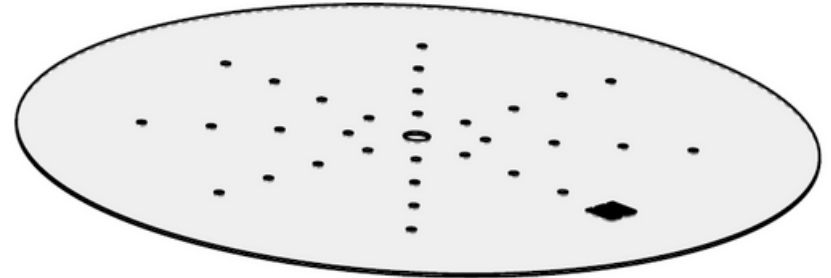

03 PERSPECTIVE

Optional Flat Tabletop Cover

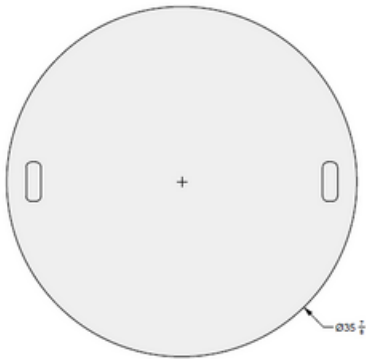

01 TOP VIEW

02 FRONT VIEW

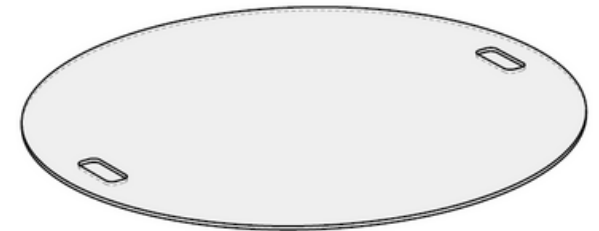

03 PERSPECTIVE