

**Size:** 48" x 32" x 16"

**The Venture Series**



## Model: Olympic Rise Fire Table

### Includes:

- Fire Table made of American sourced 3/16" mild steel or aluminum
- Warming Trends Crossfire Brass Burner (see options)
- 3/4" key valve and flex line kit for flame height adjustment (Installed by others).
- 4" chrome key and finishing plate
- Aluminum burner plate (mounted 4" below the finished top)
- 4" non-marring adjustable feet to create ventilation gap

### Optional Extras:

- 3/16" Aluminum flat cover: 28 lbs.
- Propane regulator w/10 ft hose
- Casters
- Platinum Electronic Ignition
- Mercury Battery Powered Ignition (on burners under 250K BTUs)

**Fuel Inlet Size:** 3/4" I.D. Female

**Weight:** approx. **S:** 500 lbs.  
**A:** 275 lbs.

**Fuel Pressure:** Natural Gas: 7" Water Column  
Propane: 11" Water Column

**Standard Burner:** UL130 - 130K BTUs Linear

**Upgrade:** UT170 170K BTUs Tree-Style

**Material:** 3/16" Mild Steel  
or Aluminum

**Protective Finish:** Powder Coating



**MONTANA**  
FIRE PITS

www.montanafirepits.com

### CONFIDENTIAL

Any information data and drawings embodied in this document are proprietary and strictly confidential, are to be held as confidential and supplied with the understanding that they will not be disclosed, in whole or in part or in any form, to third parties without the prior written consent of Montana Fire Pits. All information, illustrations, screen shots, and data contained are herein Copyright © Montana Fire Pits. All rights reserved.

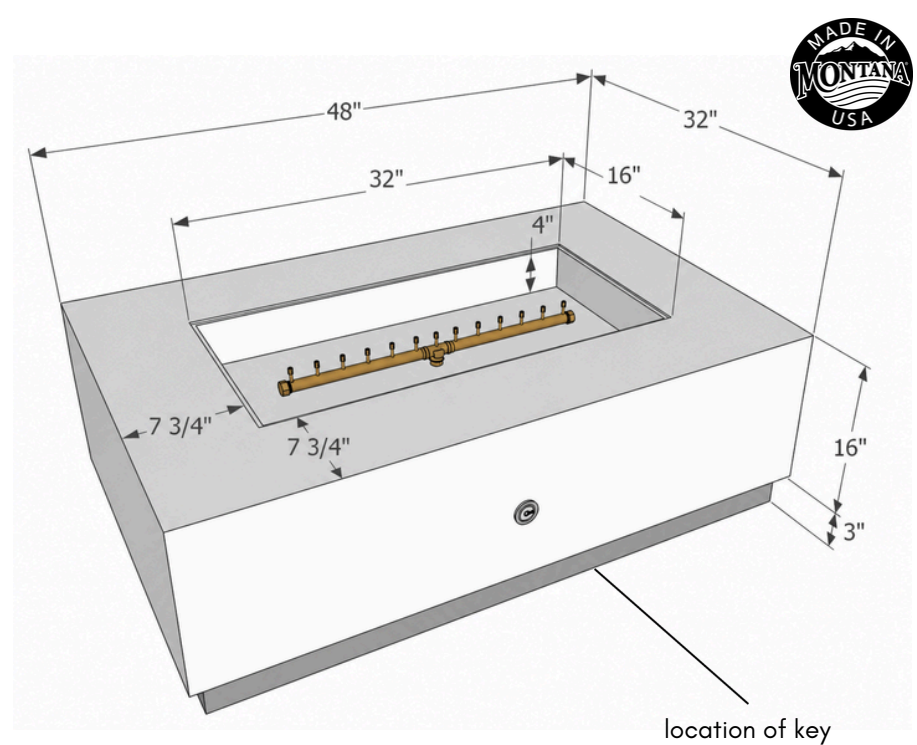

**with tree-style burner**

**Size: 55" x 32" x 16"**

**The Venture Series**



## Model: **Olympic Rise Fire Table**

### **Includes:**

- Fire Table made of American sourced 3/16" mild steel or aluminum
- Warming Trends Crossfire Brass Burner (see options)
- 3/4" key valve and flex line kit for flame height adjustment (Installed by others).
- 4" chrome key and finishing plate
- Aluminum burner plate (mounted 4" below the finished top)
- 4" non-marring adjustable feet to create ventilation gap

### **Optional Extras:**

- 3/16" Aluminum flat cover: 32 lbs.
- Propane regulator w/10 ft hose
- Casters
- Platinum Electronic Ignition
- Mercury Battery Powered Ignition (on burners under 250K BTUs)

**Fuel Inlet Size:** 3/4" I.D. Female

**Weight:** approx. **S:** 550 lbs.  
**A:** 375 lbs.

**Fuel Pressure:** Natural Gas: 7" Water Column  
Propane: 11" Water Column

**Standard Burner:** UL150 - 150K BTUs Linear

**Upgrade:** UT230 230K BTUs Tree-Style

**Material:** 3/16" Mild Steel or Aluminum

**Protective Finish:** Powder Coating



**MONTANA**  
FIRE PITS

www.montanafirepits.com

### **CONFIDENTIAL**

Any information data and drawings embodied in this document are proprietary and strictly confidential, are to be held as confidential and supplied with the understanding that they will not be disclosed, in whole or in part or in any form, to third parties without the prior written consent of Montana Fire Pits. All information, illustrations, screen shots, and data contained are herein Copyright © Montana Fire Pits. All rights reserved.

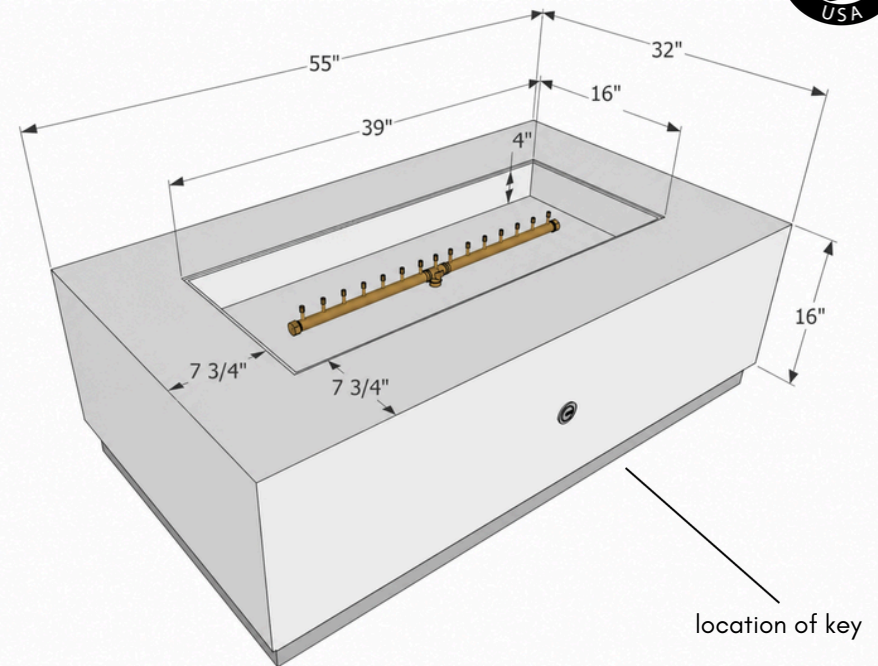

**with tree-style burner**

Size: **60" x 32" x 16"**

The Venture Series



## Model: **Olympic Rise Fire Table**

### Includes:

- Fire Table made of American sourced 3/16" mild steel or aluminum
- Warming Trends Crossfire Brass Burner (see options)
- 3/4" key valve and flex line kit for flame height adjustment (Installed by others).
- 4" chrome key and finishing plate
- Aluminum burner plate (mounted 4" below the finished top)
- 4" non-marring adjustable feet to create ventilation gap

### Optional Extras:

- 3/16" Aluminum flat cover: 35 lbs.
- Propane regulator w/10 ft hose
- Casters
- Platinum Electronic Ignition
- Mercury Battery Powered Ignition (on burners under 250K BTUs)

**Fuel Inlet Size:** 3/4" I.D. Female

**Weight:** approx. **S:** 560 lbs.

**A:** 375 lbs.

**Fuel Pressure:** Natural Gas: 7" Water Column  
Propane: 11" Water Column

**Standard Burner:** UL190 - 190K BTUs Linear

**Upgrade:** UT290 290K BTUs Tree-Style

**Material:** 3/16" Mild Steel or Aluminum

**Protective Finish:** Powder Coating

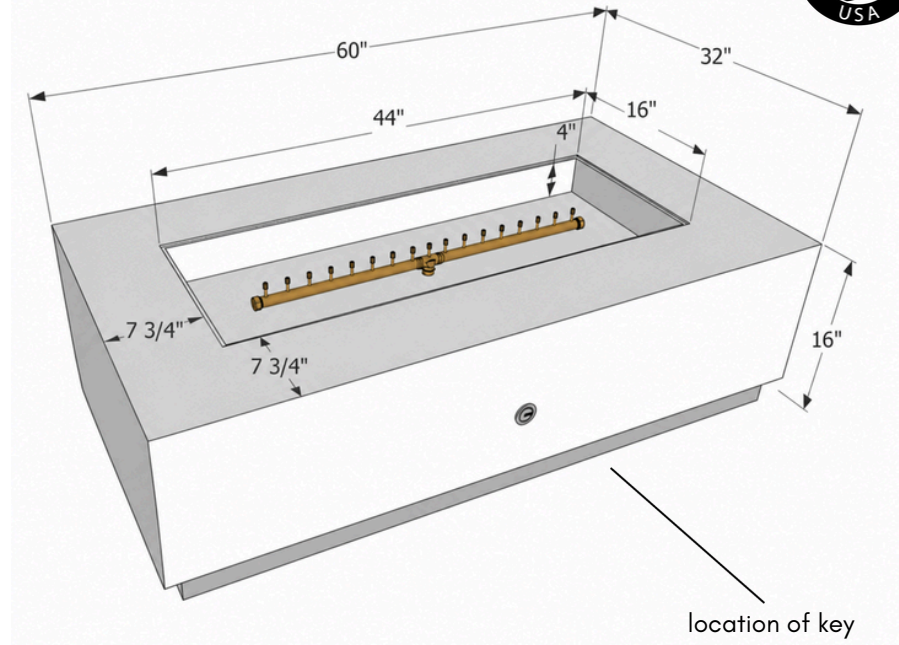

**with tree-style burner**



MONTANA  
FIRE PITS

www.montanafirepits.com

### CONFIDENTIAL

Any information data and drawings embodied in this document are proprietary and strictly confidential, are to be held as confidential and supplied with the understanding that they will not be disclosed, in whole or in part or in any form, to third parties without the prior written consent of Montana Fire Pits. All information, illustrations, screen shots, and data contained are herein Copyright © Montana Fire Pits. All rights reserved.

Size: **67" x 32" x 16"**

The Venture Series



## Model: **Olympic Rise Fire Table**

### Includes:

- Fire Table made of American sourced 3/16" mild steel or aluminum
- Warming Trends Crossfire Brass Burner (see options)
- 3/4" key valve and flex line kit for flame height adjustment (Installed by others).
- 4" chrome key and finishing plate
- Aluminum burner plate (mounted 4" below the finished top)
- 4" non-marring adjustable feet to create ventilation gap

### Optional Extras:

- 3/16" Aluminum flat cover: 40 lbs.
- Propane regulator w/10 ft hose
- Casters
- Platinum Electronic Ignition
- Mercury Battery Powered Ignition (on burners under 250K BTUs)

**Fuel Inlet Size:** 3/4" I.D. Female

**Weight:** approx. **S:** 585 lbs.  
**A:** 415 lbs.

**Fuel Pressure:** Natural Gas: 7" Water Column  
Propane: 11" Water Column

**Standard Burner:** UL210 - 210K BTUs Linear

**Upgrade:** UT290 290K BTUs Tree-Style

**Material:** 3/16" Mild Steel or Aluminum

**Protective Finish:** Powder Coating



MONTANA  
FIRE PITS

www.montanafirepits.com

#### CONFIDENTIAL

Any information data and drawings embodied in this document are proprietary and strictly confidential, are to be held as confidential and supplied with the understanding that they will not be disclosed, in whole or in part or in any form, to third parties without the prior written consent of Montana Fire Pits. All information, illustrations, screen shots, and data contained are herein Copyright © Montana Fire Pits. All rights reserved.

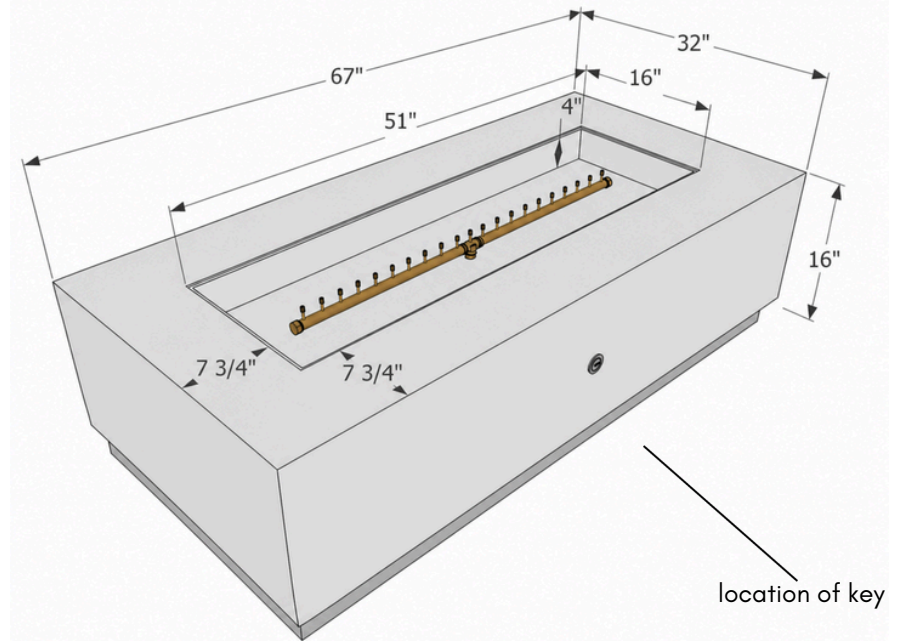

**with tree-style burner**

**Size:** 76" x 32" x 16"

**The Venture Series**



## Model: **Olympic Rise Fire Table**

### **Includes:**

- Fire Table made of American sourced 3/16" mild steel or aluminum
- Warming Trends Crossfire Brass Burner (see options)
- 3/4" key valve and flex line kit for flame height adjustment (Installed by others).
- 4" chrome key and finishing plate
- Aluminum burner plate (mounted 4" below the finished top)
- 4" non-marring adjustable feet to create ventilation gap

### **Optional Extras:**

- 3/16" Aluminum flat cover: 44 lbs.
- Propane regulator w/10 ft hose
- Casters
- Platinum Electronic Ignition
- Mercury Battery Powered Ignition (on burners under 250K BTUs)

**Fuel Inlet Size:** 3/4" I.D. Female

**Weight:** approx. **S:** 755 lbs.  
**A:** 535 lbs.

**Fuel Pressure:** Natural Gas: 7" Water Column  
Propane: 11" Water Column

**Standard Burner:** UL270 - 270K BTUs Linear  
**Upgrade:** UT350 350K BTUs Tree-Style

**Material:** 3/16" Mild Steel or Aluminum

**Protective Finish:** Powder Coating



**MONTANA**  
FIRE PITS

www.montanafirepits.com

#### **CONFIDENTIAL**

Any information data and drawings embodied in this document are proprietary and strictly confidential, are to be held as confidential and supplied with the understanding that they will not be disclosed, in whole or in part or in any form, to third parties without the prior written consent of Montana Fire Pits. All information, illustrations, screen shots, and data contained are herein Copyright © Montana Fire Pits. All rights reserved.

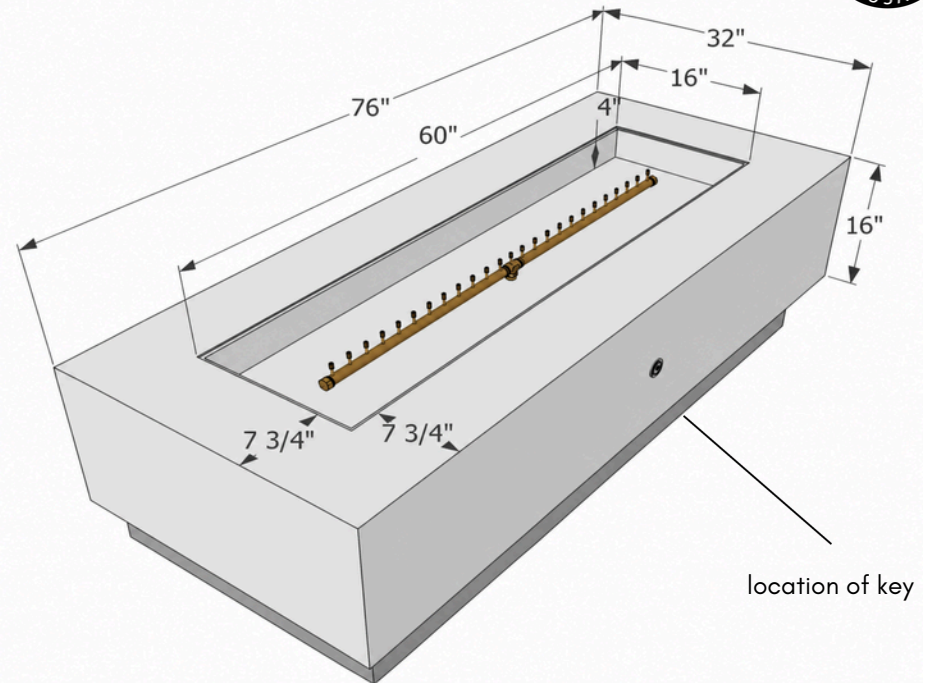

**with tree-style burner**

**Size:** 86" x 32" x 16"

**The Venture Series**



## Model: Olympic Rise Fire Table

### Includes:

- Fire Table made of American sourced 3/16" mild steel or aluminum
- Warming Trends Crossfire Brass Burner (see options)
- 3/4" key valve and flex line kit for flame height adjustment (Installed by others).
- 4" chrome key and finishing plate
- Aluminum burner plate (mounted 4" below the finished top)
- 4" non-marring adjustable feet to create ventilation gap

### Optional Extras:

- 3/16" Aluminum flat cover: 50 lbs.
- Propane regulator w/10 ft hose
- Casters
- Platinum Electronic Ignition
- Mercury Battery Powered Ignition (on burners under 250K BTUs)

**Fuel Inlet Size:** 3/4" I.D. Female

**Weight:** approx. **S:** 821 lbs.  
**A:** 532 lbs.

**Fuel Pressure:** Natural Gas: 7" Water Column  
Propane: 11" Water Column

**Burner:** UT410 - 410K BTUs Tree-Style

**Material:** 3/16" Mild Steel or Aluminum

**Protective Finish:** Powder Coating



**MONTANA**  
FIRE PITS

www.montanafirepits.com

#### CONFIDENTIAL

Any information data and drawings embodied in this document are proprietary and strictly confidential, are to be held as confidential and supplied with the understanding that they will not be disclosed, in whole or in part or in any form, to third parties without the prior written consent of Montana Fire Pits. All information, illustrations, screen shots, and data contained are herein Copyright © Montana Fire Pits. All rights reserved.

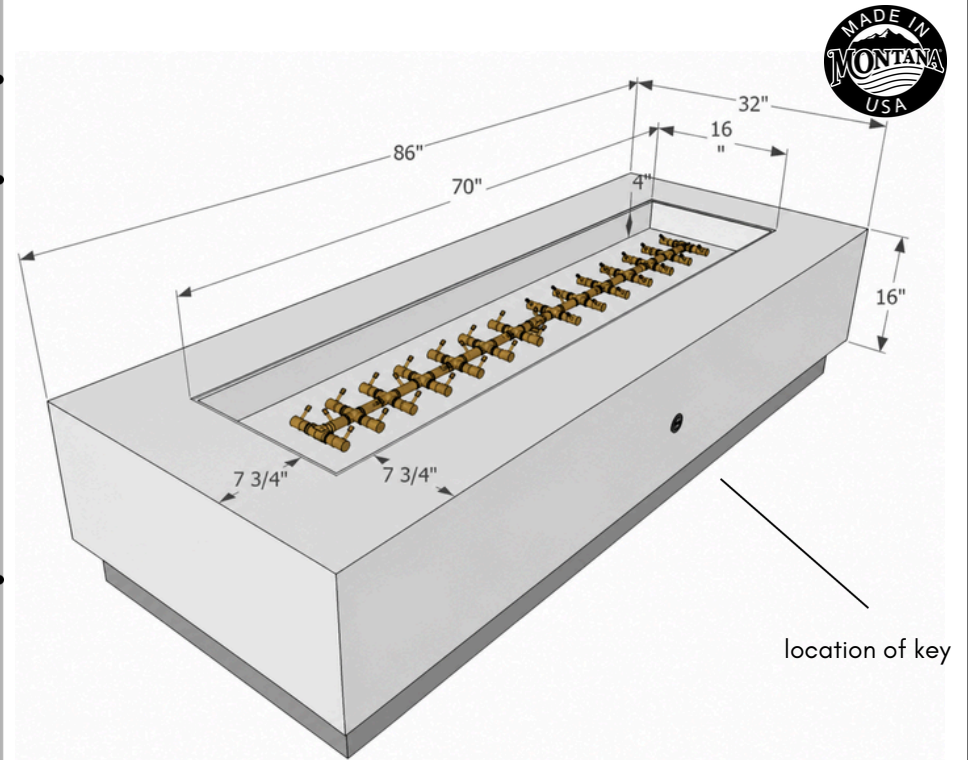

**with tree-style burner**

**Size:** 96" x 32" x 16"

**The Venture Series**



**Model: Olympic Rise Fire Table**

**Includes:**

- Fire Table made of American sourced 3/16" mild steel or aluminum
- Warming Trends Crossfire Brass Burner (see options)
- 3/4" key valve and flex line kit for flame height adjustment (Installed by others).
- 4" chrome key and finishing plate
- Aluminum burner plate (mounted 4" below the finished top)
- 4" non-marring adjustable feet to create ventilation gap

**Optional Extras:**

- 3/16" Aluminum flat cover: 56 lbs.
- Propane regulator w/10 ft hose
- Casters
- Platinum Electronic Ignition
- Mercury Battery Powered Ignition (on burners under 250K BTUs)

**Fuel Inlet Size:** 3/4" I.D. Female

**Weight:** approx. **S:** 980 lbs.  
**A:** 680 lbs.

**Fuel Pressure:** Natural Gas: 7" Water Column  
Propane: 11" Water Column

**Burner:** UT470 - 470K BTUs Tree-Style

**Material:** 3/16" Mild Steel or Aluminum

**Protective Finish:** Powder Coating



**MONTANA**  
FIRE PITS

www.montanafirepits.com

**CONFIDENTIAL**

Any information data and drawings embodied in this document are proprietary and strictly confidential, are to be held as confidential and supplied with the understanding that they will not be disclosed, in whole or in part or in any form, to third parties without the prior written consent of Montana Fire Pits. All information, illustrations, screen shots, and data contained are herein Copyright © Montana Fire Pits. All rights reserved.

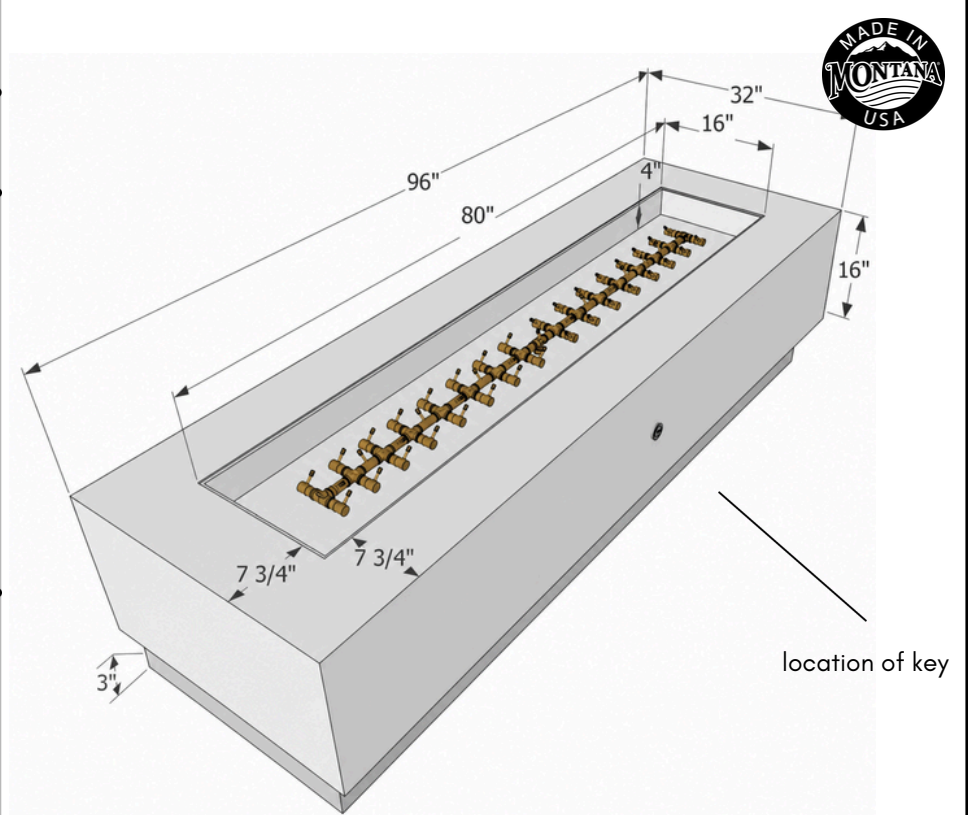

**with tree-style burner**